

- 1) Profiles shall be manufactured in accordance with NZS 3617 and or Branz Bulletin 411.
- 2) Profiles shall be fixed in accordance with E2/AS1 table 24.
- 3) Profiles shall be factory coated to all surfaces prior to delivery.

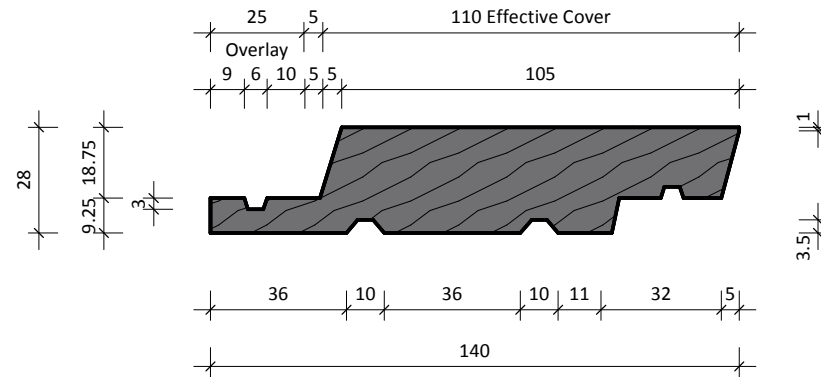

RKL703 - 28mm

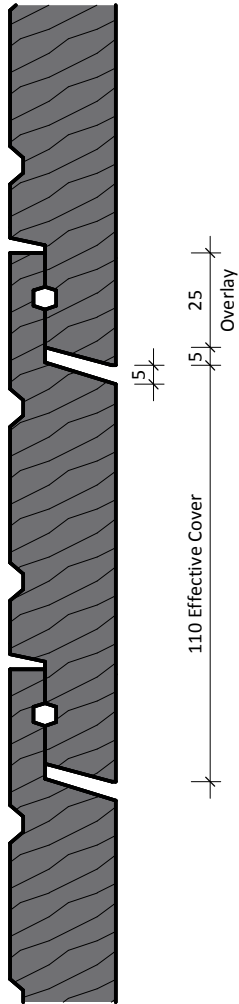

[www.rosenfeldkidson.co.nz](http://www.rosenfeldkidson.co.nz)

Auckland Branch:  
513 Mt Wellington Highway  
Mt Wellington, Auckland 1060  
T. +64 9 573 0503  
F. +64 9 573 0504

Christchurch Branch:  
15 Edmonton Road, Hornby  
Christchurch 8042  
T. +64 3 349 3316  
F. +64 3 349 3317

Title **140 x 28mm Profile**

Drawing  
**RKL703**

Scale 1 : 2 @ A4 Date 28.06.2017

- 1) Profiles shall be manufactured in accordance with NZS 3617 and or Branz Bulletin 411.
- 2) Profiles shall be fixed in accordance with E2/AS1 table 24.
- 3) Profiles shall be factory coated to all surfaces prior to delivery.

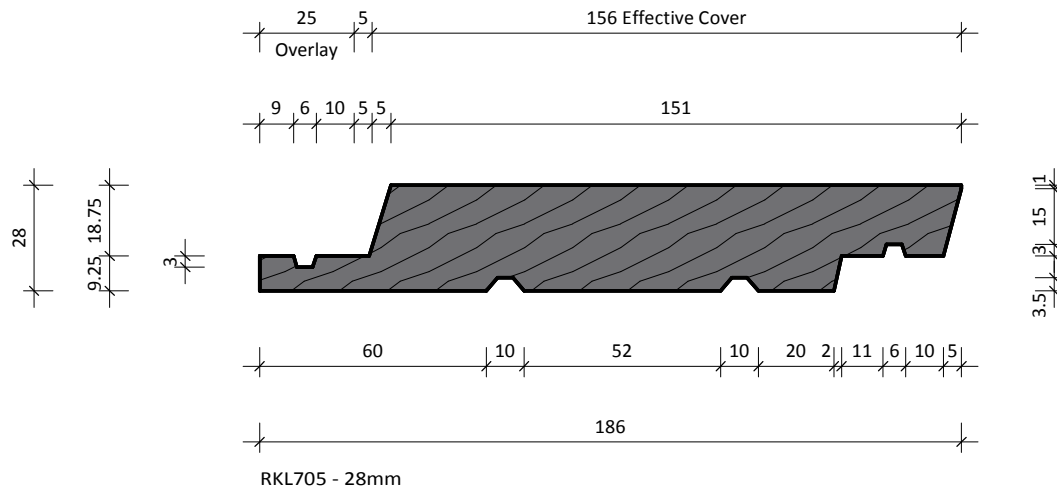
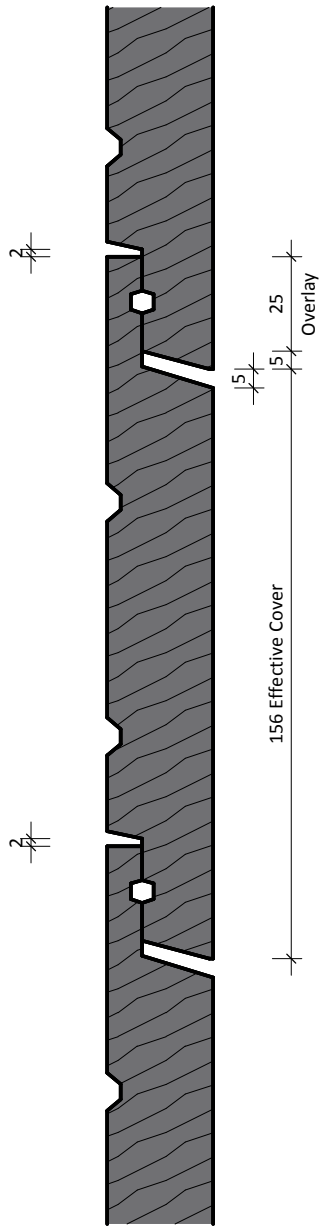

[www.rosenfeldkidson.co.nz](http://www.rosenfeldkidson.co.nz)

Auckland Branch:  
513 Mt Wellington Highway  
Mt Wellington, Auckland 1060  
T. +64 9 573 0503  
F. +64 9 573 0504

Christchurch Branch:  
15 Edmonton Road, Hornby  
Christchurch 8042  
T. +64 3 349 3316  
F. +64 3 349 3317

Title **186x28mm Profile**

Drawing  
**RKL705**

Scale 1 : 2 @ A4 Date 28.06.2017

1. Scope as per Clauses 1.0 and 9.4 E2/AS1
2. Profiles as per NZS 3617 Branz Bulletin 411
3. Fixings as per Table 24 E2/AS1
4. Compatibility of materials as per Tables 20-22 E2/AS1
5. Flashing as per Clause 4.0 E2/AS1
6. Rigid and flexible underlay as per Table 23 and Clauses 9.1.5 to 9.1.7 E2/AS1 or proprietary approved alternative
7. All weatherboards to be factory oiled to all faces and weathergrooves prior to installation
8. The weatherboard system relies on the joinery meeting the requirements of NZS 4211 for the relevant building windzone or wind pressure.

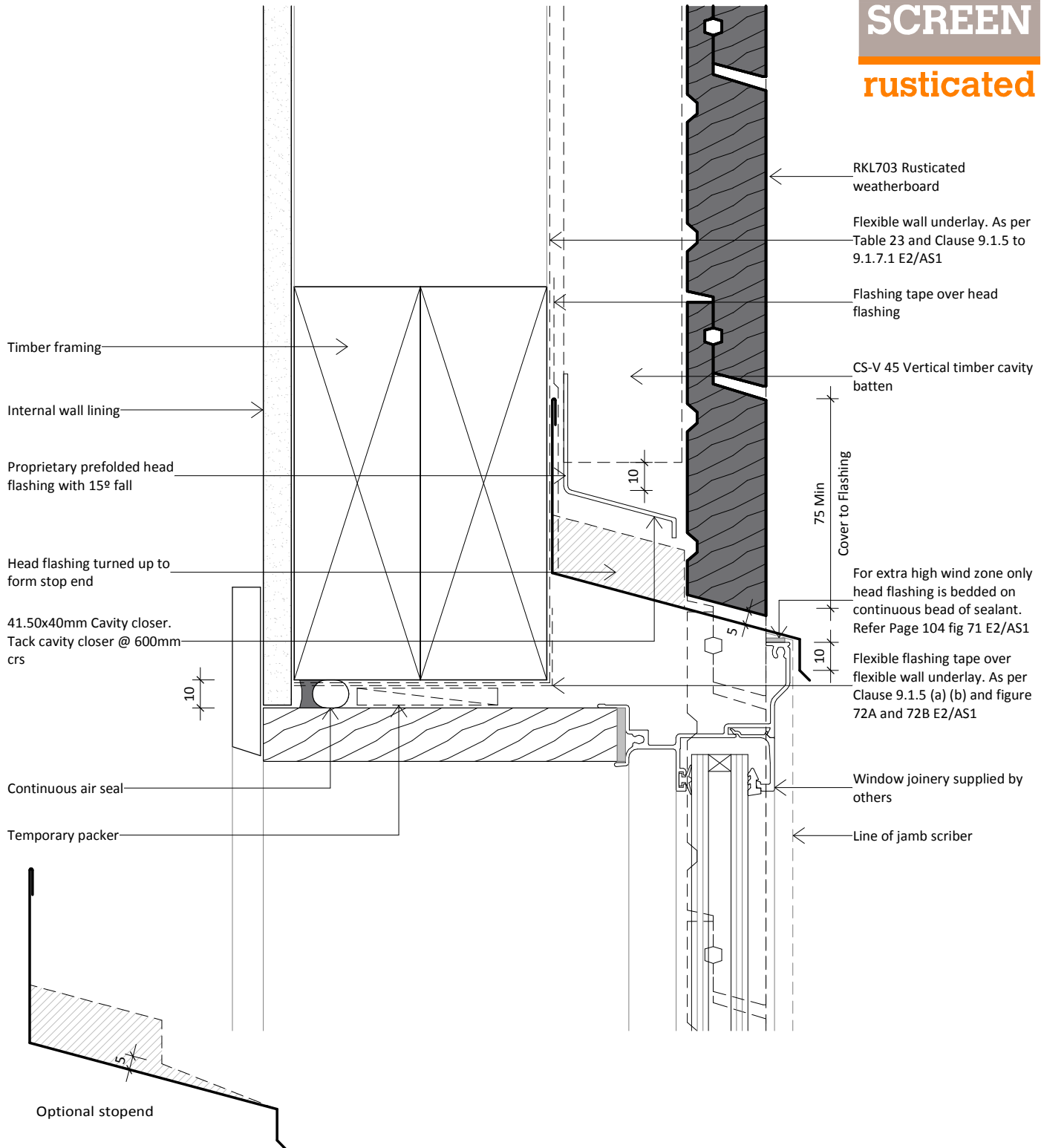

	Auckland Branch:	Christchurch Branch:	Title	<b>Aluminium Head Detail</b>
	513 Mt Wellington Highway Mt Wellington, Auckland 1060 T. +64 9 573 0503 F. +64 9 573 0504	15 Edmonton Road, Hornby Christchurch 8042 T. +64 3 349 3316 F. +64 3 349 3317	Drawing	<b>RKL HEAD</b>
www.rosenfeldkidson.co.nz	Postal address: PO Box 621, Shortland Street, Auckland 1140		Scale	1 : 2 @ A4 Date 28.06.2017

1. Scope as per Clauses 1.0 and 9.4 E2/AS1
2. Profiles as per NZS 3617 Branz Bulletin 411
3. Fixings as per Table 24 E2/AS1
4. Compatibility of materials as per Tables 20-22 E2/AS1
5. Flashing as per Clause 4.0 E2/AS1
6. Rigid and flexible underlay as per Table 23 and Clauses 9.1.5 to 9.1.7 E2/AS1 or proprietary approved alternative
7. All weatherboards to be factory oiled to all faces and weathergrooves prior to installation
8. The weatherboard system relies on the joinery meeting the requirements of NZS 4211 for the relevant building windzone or wind pressure.

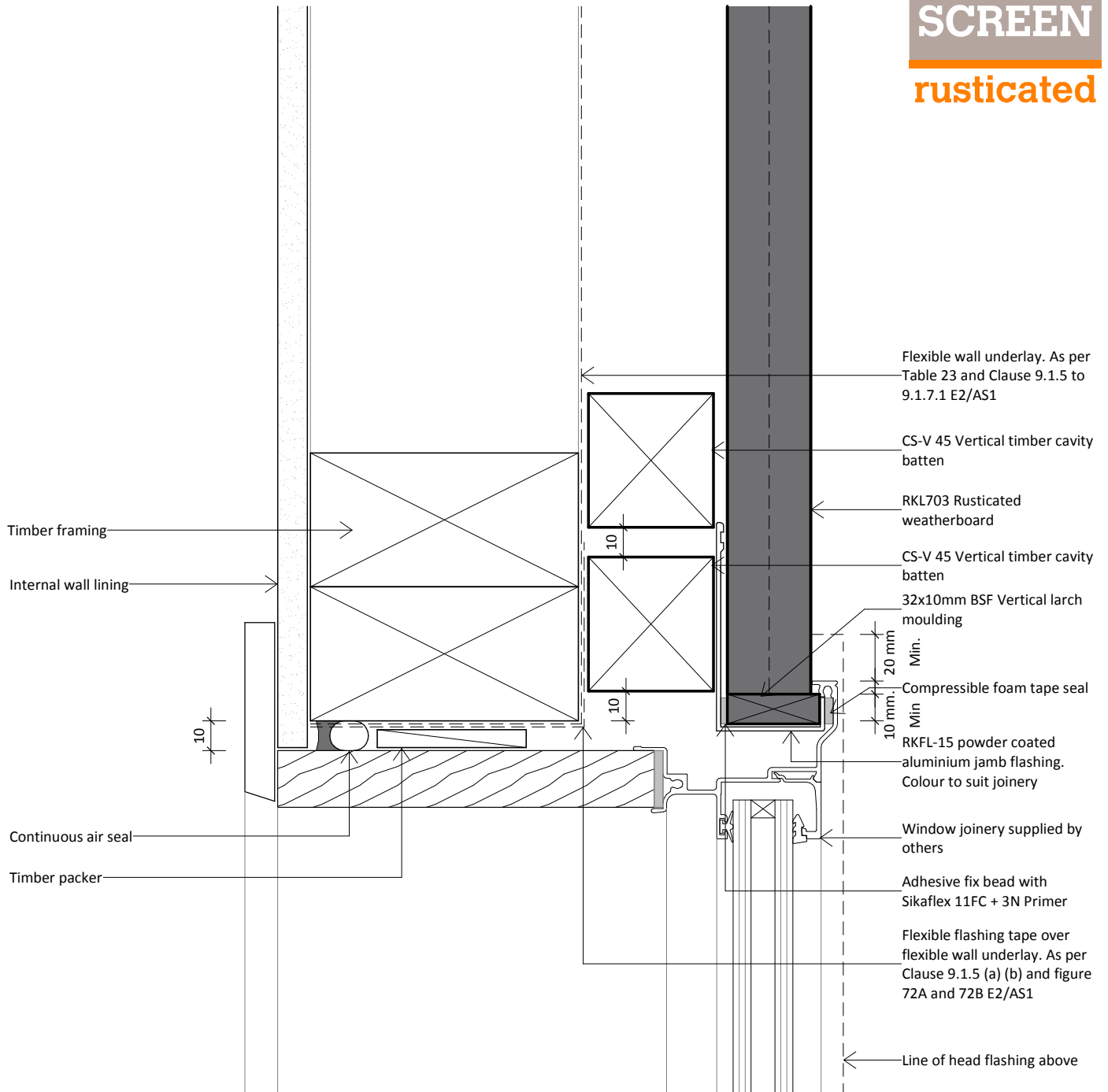

**Rosenfeld  
Kidson**

www.rosenfeldkidson.co.nz

Auckland Branch:  
513 Mt Wellington Highway  
Mt Wellington, Auckland 1060  
T. +64 9 573 0503  
F. +64 9 573 0504

Christchurch Branch:  
15 Edmonton Road, Hornby  
Christchurch 8042  
T. +64 3 349 3316  
F. +64 3 349 3317

Postal address: PO Box 621, Shortland Street, Auckland 1140

Title **Aluminium Jamb Detail**

Drawing  
**RKL JAMB**

Scale 1 : 2 @ A4 Date 28.06.2017

1. Scope as per Clauses 1.0 and 9.4 E2/AS1
2. Profiles as per NZS 3617 Branz Bulletin 411
3. Fixings as per Table 24 E2/AS1
4. Compatibility of materials as per Tables 20-22 E2/AS1
5. Flashing as per Clause 4.0 E2/AS1
6. Rigid and flexible underlay as per Table 23 and Clauses 9.1.5 to 9.1.7 E2/AS1 or proprietary approved alternative
7. All weatherboards to be factory oiled to all faces and weathergrooves prior to installation
8. The weatherboard system relies on the joinery meeting the requirements of NZS 4211 for the relevant building windzone or wind pressure.

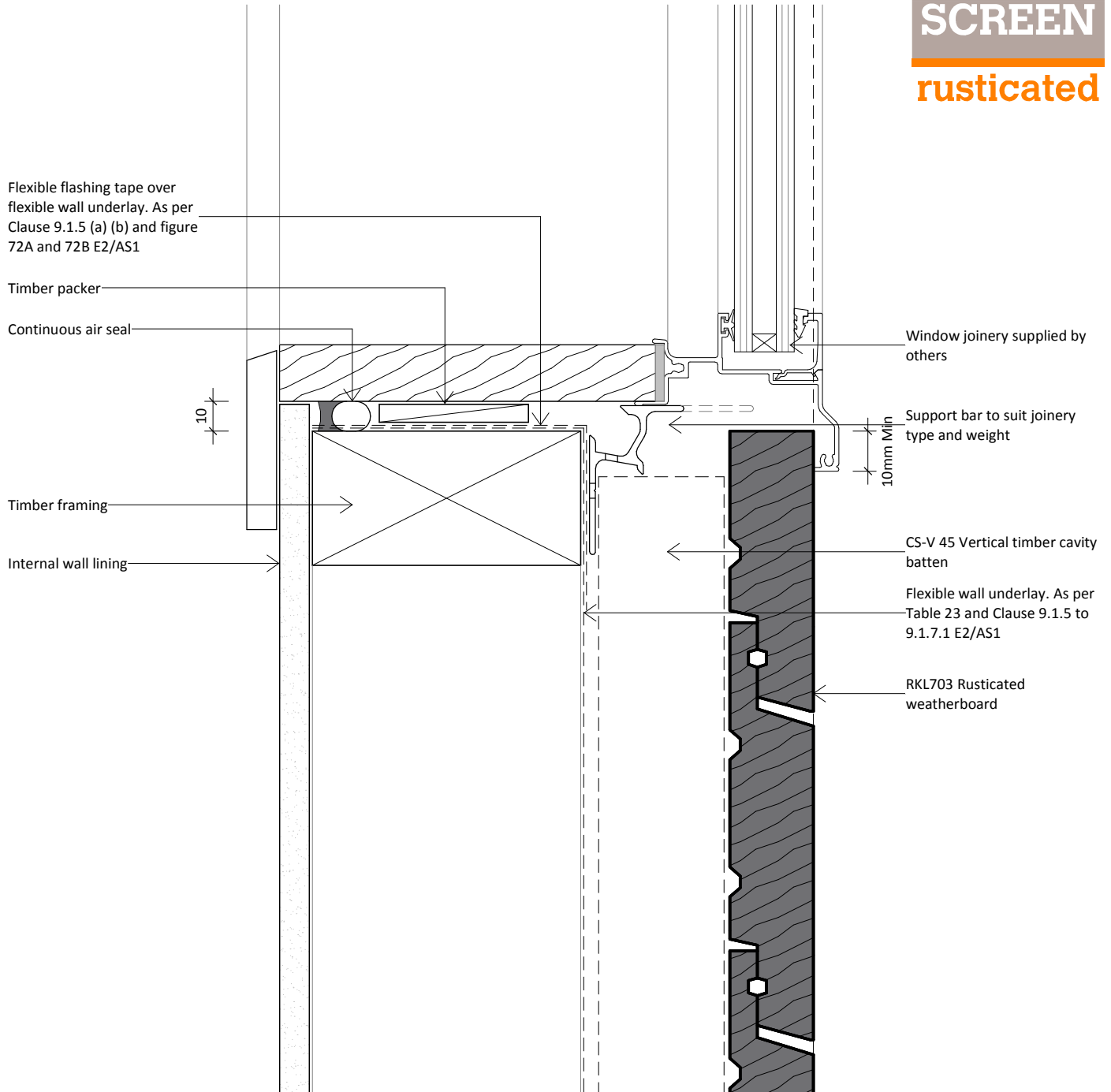

**Rosenfeld  
Kidson**

www.rosenfeldkidson.co.nz

Auckland Branch:  
513 Mt Wellington Highway  
Mt Wellington, Auckland 1060  
T. +64 9 573 0503  
F. +64 9 573 0504

Christchurch Branch:  
15 Edmonton Road, Hornby  
Christchurch 8042  
T. +64 3 349 3316  
F. +64 3 349 3317

Postal address: PO Box 621, Shortland Street, Auckland 1140

Title **Aluminium Sill Detail**

Drawing

**RKL SILL**

Scale 1 : 2 @ A4

Date 28.06.2017

1. Scope as per Clauses 1.0 and 9.4 E2/AS1
2. Profiles as per NZS 3617 Branz Bulletin 411
3. Fixings as per Table 24 E2/AS1
4. Compatibility of materials as per Tables 20-22 E2/AS1
5. Flashing as per Clause 4.0 E2/AS1
6. Rigid and flexible underlay as per Table 23 and Clauses 9.1.5 to 9.1.7 E2/AS1 or proprietary approved alternative
7. All weatherboards to be factory oiled to all faces and weathergrooves prior to installation
8. The weatherboard system relies on the joinery meeting the requirements of NZS 4211 for the relevant building windzone or wind pressure.

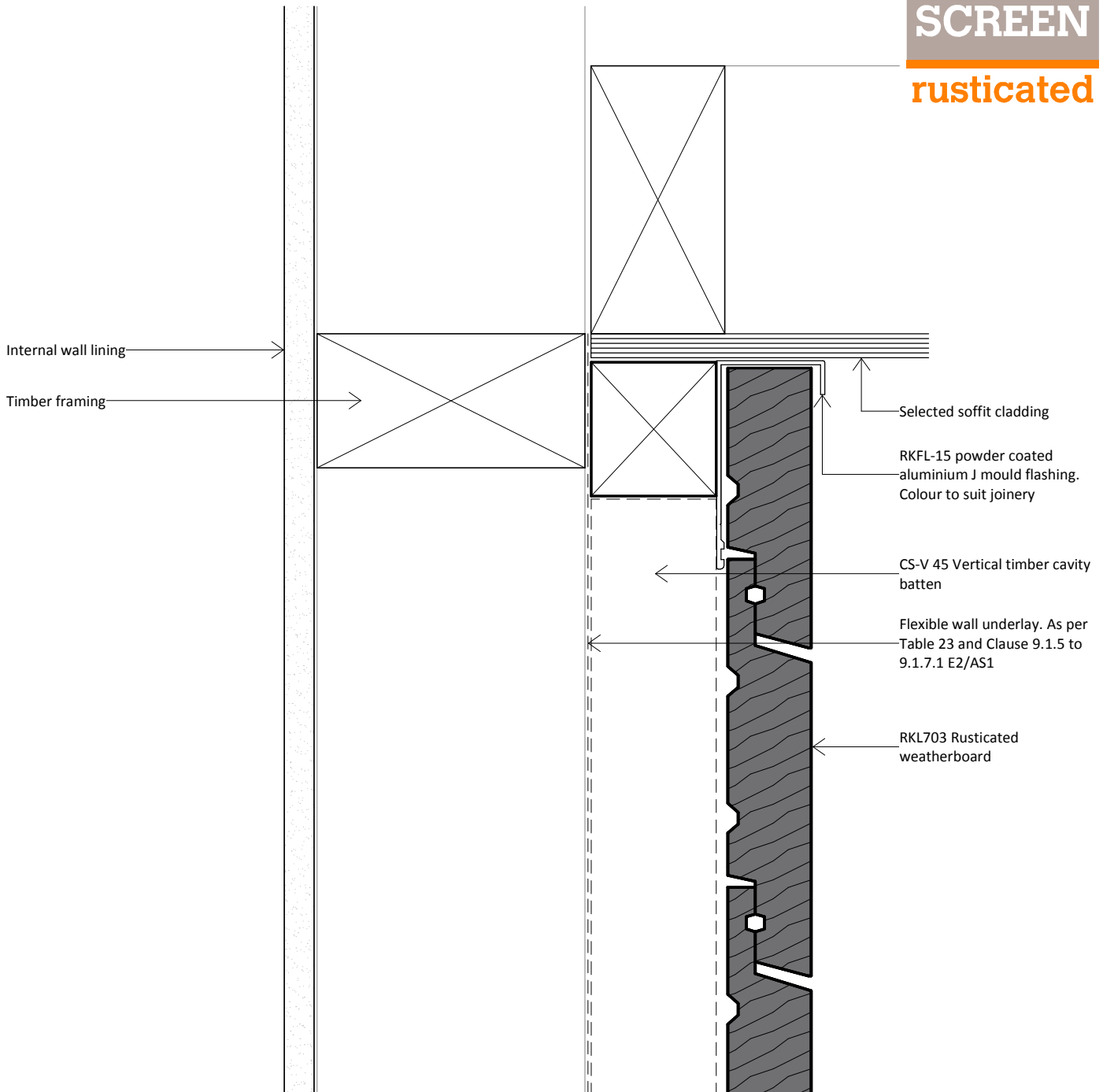

**Rosenfeld  
Kidson**

www.rosenfeldkidson.co.nz

Auckland Branch:  
513 Mt Wellington Highway  
Mt Wellington, Auckland 1060  
T. +64 9 573 0503  
F. +64 9 573 0504

Christchurch Branch:  
15 Edmonton Road, Hornby  
Christchurch 8042  
T. +64 3 349 3316  
F. +64 3 349 3317

Postal address: PO Box 621, Shortland Street, Auckland 1140

Title **Top Plate to Soffit Detail**

Drawing

**RKL SOFFIT**

Scale 1 : 2 @ A4

Date 28.06.2017

1. Scope as per Clauses 1.0 and 9.4 E2/AS1
2. Profiles as per NZS 3617 Branz Bulletin 411
3. Fixings as per Table 24 E2/AS1
4. Compatibility of materials as per Tables 20-22 E2/AS1
5. Flashing as per Clause 4.0 E2/AS1
6. Rigid and flexible underlay as per Table 23 and Clauses 9.1.5 to 9.1.7 E2/AS1 or proprietary approved alternative
7. All weatherboards to be factory oiled to all faces and weathergrooves prior to installation
8. The weatherboard system relies on the joinery meeting the requirements of NZS 4211 for the relevant building windzone or wind pressure.

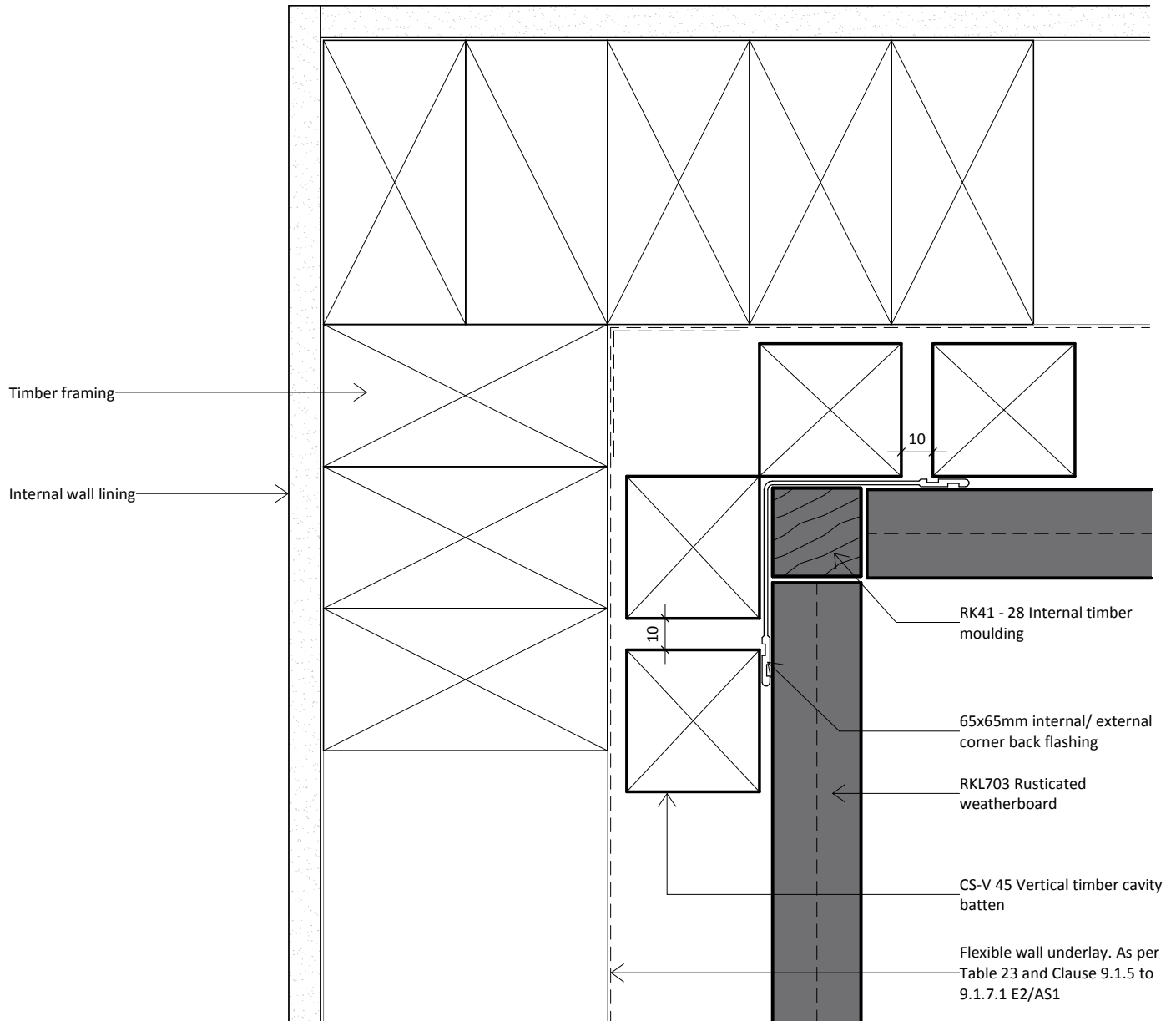

**Rosenfeld  
Kidson**

www.rosenfeldkidson.co.nz

Auckland Branch:  
513 Mt Wellington Highway  
Mt Wellington, Auckland 1060  
T. +64 9 573 0503  
F. +64 9 573 0504

Christchurch Branch:  
15 Edmonton Road, Hornby  
Christchurch 8042  
T. +64 3 349 3316  
F. +64 3 349 3317

Postal address: PO Box 621, Shortland Street, Auckland 1140

Title **Internal Corner Detail  
Option**

Drawing

**RKL-R-11A**

Scale 1 : 2 @ A4

Date 28.06.2017

1. Scope as per Clauses 1.0 and 9.4 E2/AS1
2. Profiles as per NZS 3617 Branz Bulletin 411
3. Fixings as per Table 24 E2/AS1
4. Compatibility of materials as per Tables 20-22 E2/AS1
5. Flashing as per Clause 4.0 E2/AS1
6. Rigid and flexible underlay as per Table 23 and Clauses 9.1.5 to 9.1.7 E2/AS1 or proprietary approved alternative
7. All weatherboards to be factory oiled to all faces and weathergrooves prior to installation
8. The weatherboard system relies on the joinery meeting the requirements of NZS 4211 for the relevant building windzone or wind pressure.

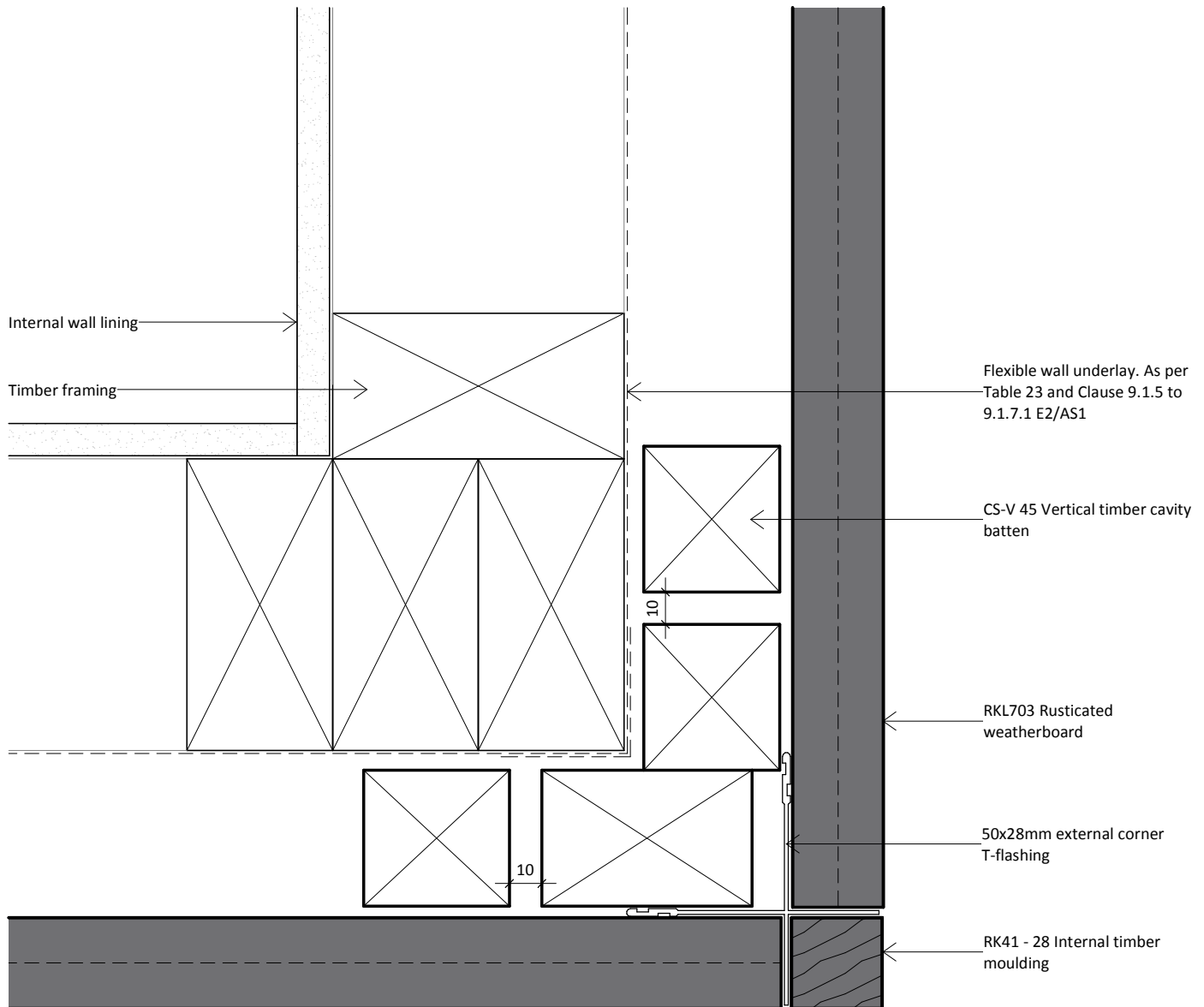

**Rosenfeld  
Kidson**

www.rosenfeldkidson.co.nz

Auckland Branch:  
513 Mt Wellington Highway  
Mt Wellington, Auckland 1060  
T. +64 9 573 0503  
F. +64 9 573 0504

Christchurch Branch:  
15 Edmonton Road, Hornby  
Christchurch 8042  
T. +64 3 349 3316  
F. +64 3 349 3317

Postal address: PO Box 621, Shortland Street, Auckland 1140

Title **External Corner Detail  
Option**

Drawing

**RKL-R-21A**

Scale 1 : 2 @ A4

Date 28.06.2017